

ACME BED BASE

Step 1 Position the corner of one End Panel inside the end of a Side Panel as displayed in the Step 1 diagram. Position the Tubular Leg inside the corner of the panels as shown. Place one Mattress Support parallel across the top of the End Panel, being careful to point the bent ends upward. Tighten screw through Mattress Support, Side Panel, End Panel, and into Tubular Leg.

Note: Do not tighten screws completely until assembly is complete.

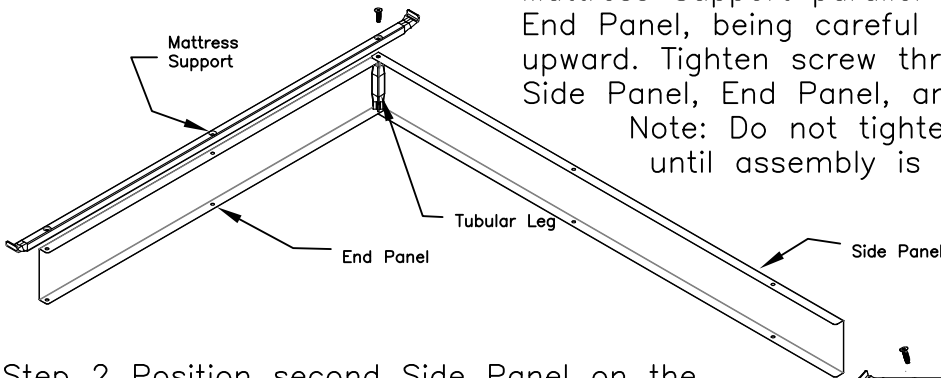

Step 2 Position second Side Panel on the other end of the End Panel and repeat assembly as in step 1. Add the front center Tubular Leg as displayed in step 2 diagram.

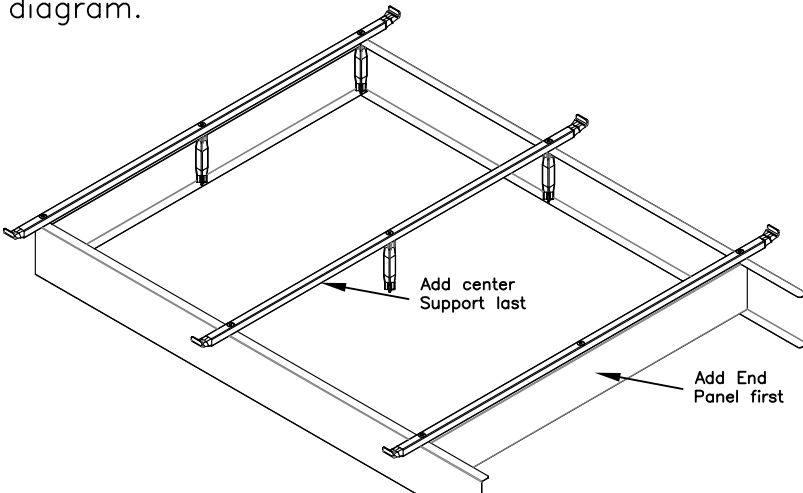
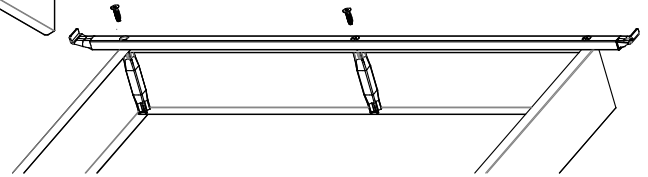

Step 3 Add the second End Panel, Mattress Support, and Tubular Legs on the opposite end of the Side Panels and assemble as instructed in Step 1. Then add center Mattress Support & Tubular Legs.

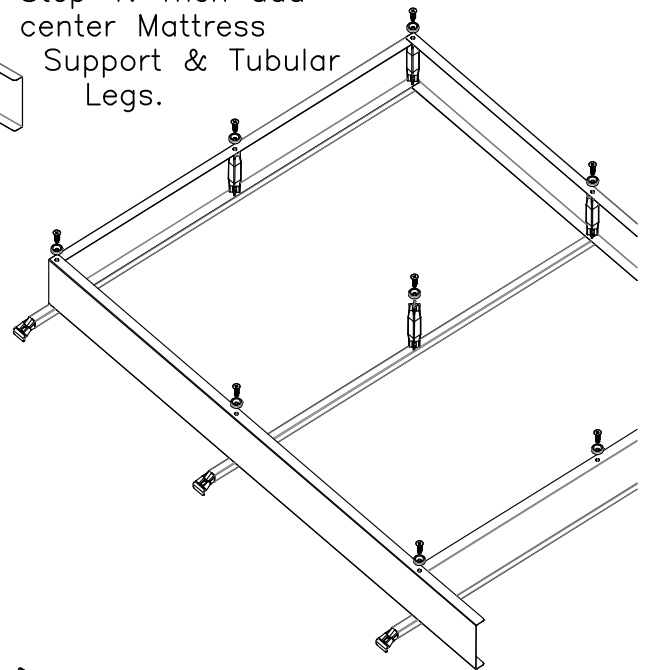

Step 4 Turn Bed Base upside down. Tighten screws through Glide Washers, Panels, and into the Tubular Legs.

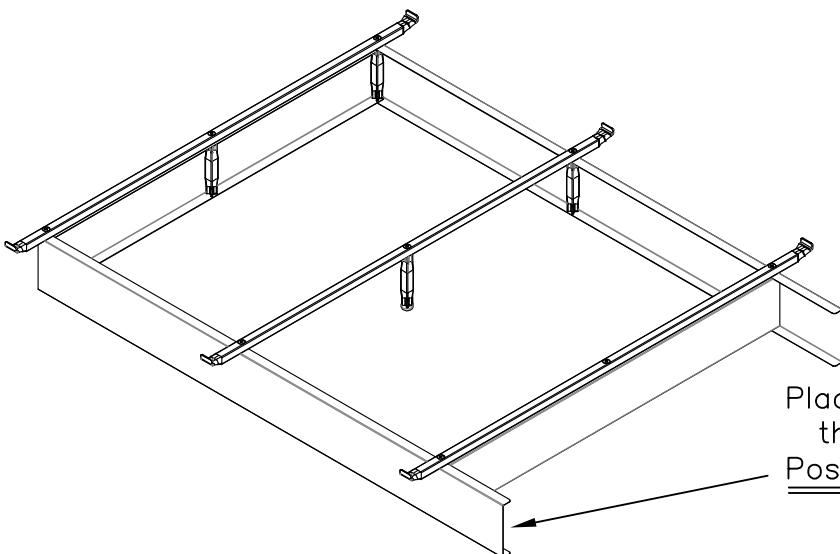

Step 5 Turn Bed Base upright. Place Vinyl End Caps on the ends of the Mattress Supports. Position this end toward the wall.

ACME BED BASE

Parts List:

A

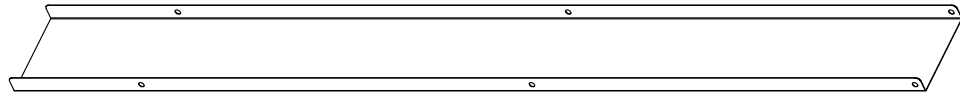

Side Panel (Quantity: 2)

B

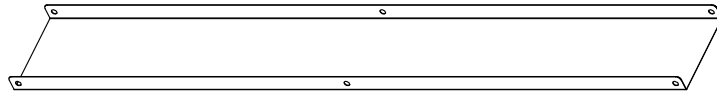

End Panel (Quantity: 2)

C

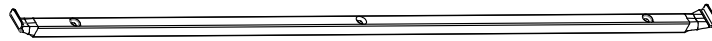

Mattress Supports (Quantity: 3)

D

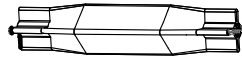

Tubular Legs (Quantity: 9)

E



Flat Head Screws (Quantity: 18)

F



Glide Washers (Quantity: 9)

G



Vinyl End Cap (Quantity: 6)